



BF46002 TOUGH PROTECTION



WITH
HIGHLY
**ENGINEERED
MEDIA**

FOR CUMMINS QSK MCERS ENGINES



HIGH EFFICIENCY TOUGH PROTECTION **BF46002**



Stricter emission regulations have forced engine manufacturers to design cleaner, more efficient engines. These new engine systems require higher fuel pressures (up to 60,000 psi) and tighter tolerances. Microscopic particles in the fuel (as small as 2 to 3 microns) under high pressure, can cause abrasive wear, severely damaging fuel injection system components.

With so much at risk, today's equipment manufacturers require fuel entering the fuel injection system to be clean and free of contaminants, meeting strict ISO 4406 fuel cleanliness level of 12/9/6. Baldwin Filters' BF46002, with Highly Engineered Layered Media (HELM™), helps prevent premature injector wear and costly downtime by keeping fuel pristine and high-precision fuel systems operating at maximum efficiency.

CLEANER FUEL EQUALS **LONGER ENGINE LIFE**

The Baldwin BF46002 fuel filter, with highly engineered layered media, succeeds in removing the smallest contaminants to ensure clean fuel flowing to sensitive fuel system components.

- **Dual-stage design catches and holds damaging microscopic particles even under high vibration**
- **Surpasses the OE by over 25% in contaminant holding capacity**
- **More efficient than the OE in removing harmful particles in the critical 2-5 micron range**

THE NEXT GENERATION OF **HIGHLY ENGINEERED MULTI-LAYER MEDIA**

Baldwin's research, development and production capabilities are unsurpassed in the industry.

The BF46002 is the first fuel filter to take advantage of our new media technology developed at our Innovation Center. The BF46002, with highly engineered layered media, is designed to trap and hold more contaminants to protect high-pressure fuel systems.

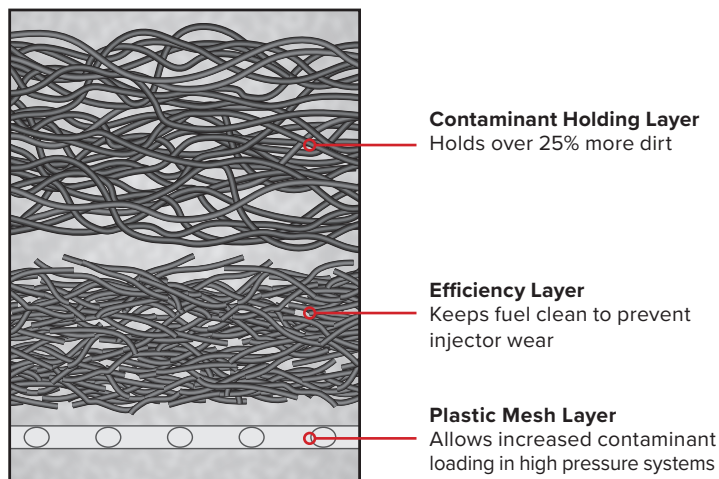

DUAL-STAGE DESIGN PROVIDES EXTRA PROTECTION

The outside to inside dual-stage element design of the BF46002 provides extra protection and ensures filtration efficiency is maintained under harsh vibration conditions. Fuel is filtered twice to ensure the fuel entering the injection system is pristinely clean.

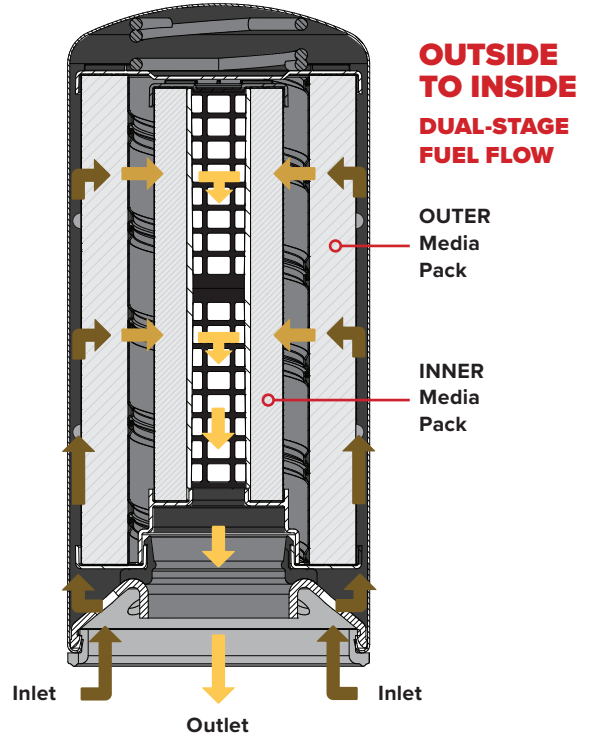
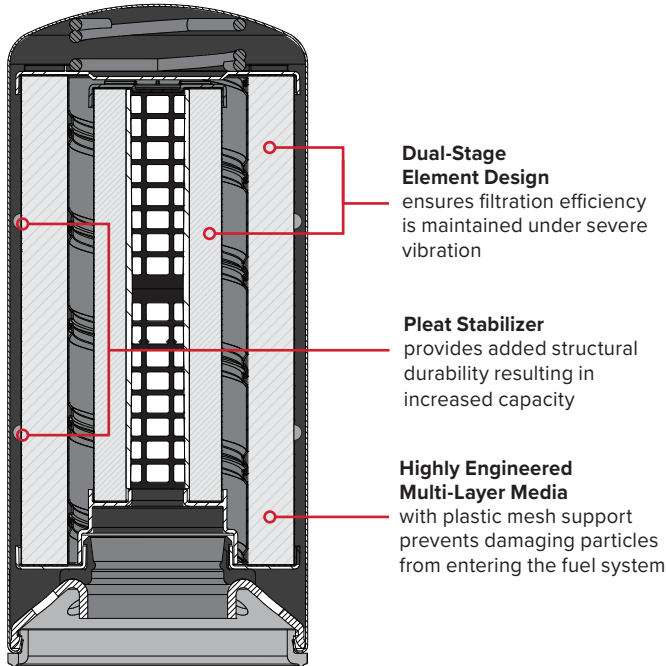

OUTPERFORMS THE OE

Side-by-side comparisons prove the BF46002 outperforms the OE by over 25% in contaminant holding capacity, resulting in longer service life and less downtime. Industry standard tests show the Baldwin BF46002 is built to perform with greater efficiency than the OE in removing critical contaminants under 5 microns.

And it doesn't stop there, Baldwin Filters has taken testing of the BF46002 beyond industry standard. Proprietary test methods, using real-world fuel, show the OE filter plugged faster than the BF46002. The BF46002 filtered more gallons of fuel than the OE when taken to the same terminal pressure drop and did a better job of catching and holding particles greater than 4 microns.

HOLDS MORE

CAPACITY (g)

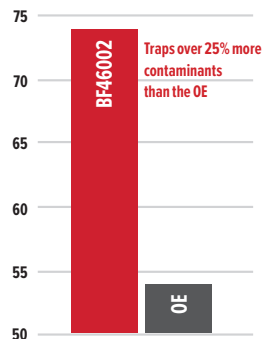

CLEANS BETTER

EFFICIENCY vs PARTICLE SIZE

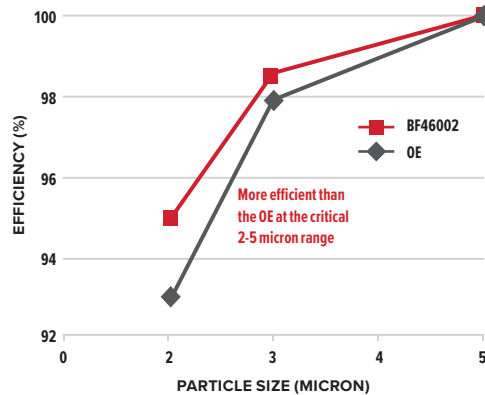

LASTS LONGER

FUEL CLEANLINESS

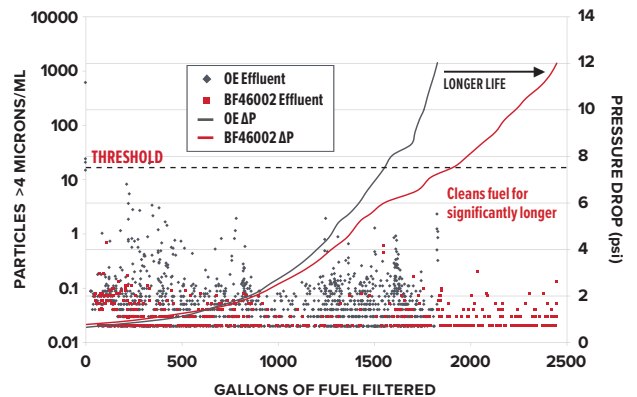

ISO 19438 Test:
Flow Rate 3 gpm, ISO Medium Test
Dust, 104°F, Termination at 5 psid

ISO 19438* Test: Flow Rate 3 gpm,
ISO Medium Test Dust, 104°F, Termination at 5 psid
* Includes 2 micron particle measurements

Proprietary Real-World Test:
ISO 4406 Fuel Cleanliness Levels >4 Micron

TOUGHER REQUIREMENTS FOR CLEANER FUEL

Due to tight tolerances between moving components of a fuel injection system, microscopic particles can cause severe damage to injectors and other fuel system components.

More and more High Pressure Common Rail fuel system and Tier 4 engine manufacturers require diesel fuels meet ISO 4406 12/9/6 cleanliness level before it reaches the pressurized fuel system.

ISO 4406 12/9/6 CLEANLINESS CODE

- Required by diesel fuel injector manufacturers
- 64 times cleaner than fuel entering equipment at manufacturer recommended ISO 4406 18/16/13 cleanliness level
- Noncompliance may void engine warranties

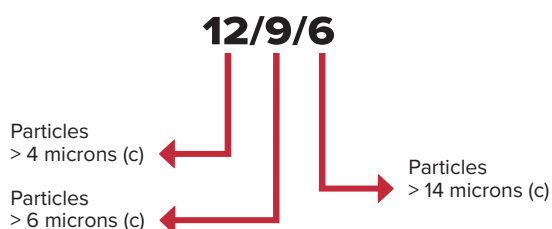

ISO CODE NUMBER	MICRON PARTICLE SIZE	ACTUAL PARTICLE COUNT RANGE (per ml of fluid sample)
12	> 4 micron (c)	> 20 - 40
9	> 6 micron (c)	> 2.5 - 5
6	> 14 micron (c)	> 0.3 - 0.6

ISO CODE NUMBER	NUMBER OF PARTICLES PER ML	
	(MORE THAN)	(UP TO & INCLUDING)
28	1,300,000	2,500,000
27	640,000	1,300,000
26	320,000	640,000
25	160,000	320,000
24	80,000	160,000
23	40,000	80,000
22	20,000	40,000
21	10,000	20,000
20	5,000	10,000
19	2,500	5,000
18	1,300	2,500
17	640	1,300
16	320	640
15	160	320
14	80	160
13	40	80
12	20	40
11	10	20
10	5	10
9	2.5	5
8	1.3	2.5
7	0.6	1.3
6	0.3	0.6

CROSS-REFERENCE GUIDE									
BALDWIN	CUMMINS	DONALDSON	FLEETGUARD	HIFI/JURA	LUBER-FINER	MANN & HUMMEL	RYCO	SF - FILTER	WIX
BF46002	2881458	DBF5782	FF5782	SN40698	LFF5644	WK12010	---	SK3056/2	WF10144

APPLICATION GUIDE
Euclid, Hitachi, John Deere, Kawasaki, Komatsu, Liebherr, Terex Heavy-Duty Off-Road Equipment all with Cummins QSK MCRS Engines (19L, 38L, 50L, 60L)

For complete engine filter listings visit www.baldwinfilter.com



800.822.5394 | baldwinfilter.com

Designed and manufactured in the USA.
Form 603 (R 9/18) © 2018 Baldwin Filters, a Parker Hannifin Company
Printed in the U.S.A.

WARNING: These products can expose you to chemicals, including Diisononyl Phthalate, Carbon black extracts, Nickel, 1,3 Butadiene, Ethylene Oxide, Epichlorohydrin, which are known to the State of California to cause cancer, and Bisphenol-A, Ethylene Glycol, Ethylene Oxide, 1,3 Butadiene, Epichlorohydrin, which are known to the State of California to cause birth defects or other reproductive harm. For more information go to www.P65Warnings.ca.gov.