



# 150 SERIES

Diesel  
Fuel/Water  
Separators



- Installation
- Operation
- Parts
- Service Information

## INSTALLATION

### A. FILTER MOUNTED ABOVE FUEL STORAGE TANK

1. Select a location in the fuel line between the fuel tank and the fuel pump, ahead of the vacuum side filters. All secondary or pressure side filters located between the pump and the engine should be serviced and left in place.
2. Mount the DAHL unit vertically on the vacuum (suction) side of all fuel pumps in a convenient location for servicing and inspection of contaminants in the bowl. Locate the height of the unit between the bottom of the fuel tank and the inlet of the fuel pump if possible. See Figure 1.

FIGURE 1

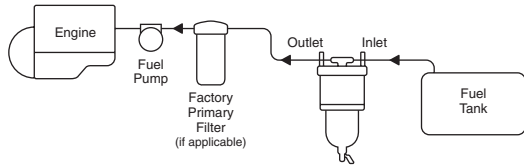

DAHL recommends a 286-SK Mounting Bracket Shock Pad Kit if the filter will be subject to excessive vibration.

### B. FILTER MOUNTED BELOW FUEL STORAGE TANK

Installation procedures are the same as above plus an addition to Step 3: A ball- or butterfly-type shut-off valve must be installed ahead of the DAHL unit INLET. See Figure 2. This valve is necessary to shut off fuel when changing the element. Valves are available from your dealer.

**NOTE:** Valve not required when installing DAHL valved manifold units.

- NOTE:** Allow 2 inches vertical clearance below the unit for servicing the element and draining the contaminants.
3. Install the fuel line from the fuel tank to the DAHL filter INLET using appropriate non-galvanized fittings. See DAHL Fittings Chart below.
  4. Install the fuel line from the DAHL filter OUTLET to the INLET of the transfer or fuel pump.

**NOTE:** To obtain maximum element life, remove as much mechanical restriction as possible from the system by doing the following:

- a. Remove the primary filter (if this does not affect warranty).
- b. Use the largest diameter fuel line that is practical.
- c. Mount the unit as near to the level of the pump as possible.
- d. Eliminate sharp bends in the fuel lines wherever possible.

The best indicator of a fuel element's condition is a vacuum gauge. (See Vacuum Gauges in Form 4005.) A tapped fitting is recommended for mounting the gauge on the OUTLET port of the DAHL filter unit. (Manifold units are already tapped and plugged.) Remove the 1/8 inch plug and install the vacuum gauge there. Fittings and gauges are available from your dealer, or contact Baldwin Filters. Prime the filter as indicated under ELEMENT REPLACEMENT section.

FIGURE 2

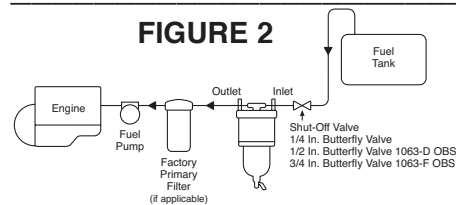



### C. STANDARD FITTINGS INSTALLATION/DAHL FITTINGS CHART

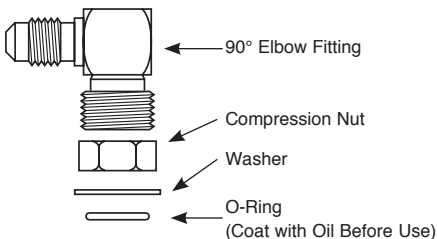

MODEL 150

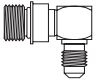
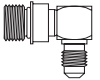
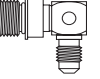
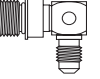
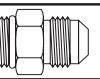
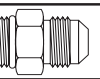
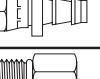
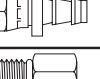
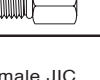
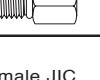

**Note:** Mount Model Before Installing Fittings. O-Ring Seal Fittings Require Care in Installation. **DO NOT OVERTIGHTEN.** See Instructions Below.

FITTING		THREAD 1	THREAD 2
90° Elbow Straight Thread with O-Ring/37° Male JIC	1  2 	7/8-14 UNF 7/8-14 UNF	3/4-16 7/8-14
90° Elbow Straight Thread with O-Ring/37° Male JIC Drilled & Tapped for #4 Vacuum Gauge Hose	1  2 	7/8-14 UNF 7/8-14 UNF 7/8-14 UNF 7/8-14 UNF	3/4-16 3/4-16 3/4-16 7/8-14
37° Male JIC Straight Thread with O-Ring	1  2 	7/8-14 UNF 7/8-14 UNF	3/4-16 7/8-14
37° Female JIC Swivel-Push-On Hose Fitting	1  2 	3/4-16 7/8-14	1/2 Hose 5/8 Hose
Female Pipe Straight Thread with O-Ring	1  2 	7/8-14 UNF 7/8-14 UNF 7/8-14 UNF	3/8-18 NPT 1/2-14 NPT 3/4-14 NPT
90° Swivel Elbow Straight Thread with O-Ring/37° Female JIC Drilled & Tapped for #4 Vacuum Gauge Hose	1  2 	7/8-14 UNF	1/2-14

**1** Install "Out" Port First

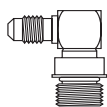

Adjust Compression Nut All the Way Back

**2** Screw in O-Ring fitting until washer contacts port



YES

(Important: Do Not Tighten Further)

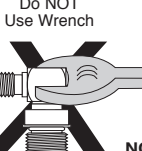

NO

**3**

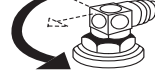

Turn Fitting Counterclockwise to Desired Position

**4** Hold fitting by hand in desired position and tighten compression nut with wrench.



CAUTION: Use Low Torque: No More Than 8 Foot Pounds

**NOTE:** Use Same Procedure for "In" Port.

# SERVICING

## DRAINING WATER

**NOTE:** The bowl should always be drained before water or contaminant levels reach the bottom of the depressurizer cone. Check daily with the engine off. Always open the draincock completely to flush particulates out. Failure to do so could cause a leaky valve.

### A. DAHL Units Mounted HIGHER Than Fuel Storage Tank

1. Turn engine off.
2. Open the primer plug to vent the filter and then open the draincock to drain all contaminants.

3. Close the draincock and follow the priming instructions shown below.

### B. DAHL Units Mounted LOWER Than Fuel Storage Tank

1. Turn engine off and close shut-off valve. (Valved Manifold units may be drained and elements replaced with the engine running at idle. Close inlet and outlet valves to isolate the filter being serviced.)
2. Open the draincock completely and drain all contaminants.
3. Close the draincock and follow the priming instructions shown below.

## ELEMENT REPLACEMENT

### A. When To Replace

As a general guideline, depending on fuel quality and engine use, elements should be replaced as follows:

1. DAHL 151 is a 2 micron element which can be used approximately 500 hours or 20,000 miles. (DAHL 151-W is a 10 micron element for use in winter or severe applications and DAHL 151-30 is a 30 micron element.)
2. If you have a vacuum gauge, the first replacement should be made at the very first indication of power loss at high RPMs. Make a note of the vacuum gauge reading at this point. The differences in various fuel system requirements make it impossible to predict what this reading will be. Mark the reading on the gauge dial or the unit for future element replacement.

### B. How To Replace Contaminated Element

1. Open the draincock completely to empty the bowl and flush particulates out. Failure to do so could cause a leaky valve.
2. Loosen the T-Bolt handle to release the filter body from the lid. (It is not necessary to completely remove the T-Bolt from the DAHL filter lid.) Support the filter body with your hand prior to release.
3. Remove the element with a turning motion. At this point,

you may clean the outside of the filter body. Use only clean diesel fuel or kerosene and wipe clean.

4. Check the centerpipe O-Ring and replace if hard or damaged.
5. Remove and replace the lid cover gasket. Be sure the lid groove and body lip are clean. (Grease the lid cover gasket to hold it in place before positioning.)

### C. Reassembly

1. Lubricate the top and bottom element gaskets. Install the element onto the centerpipe with a turning motion.
2. Fill the filter body with clean diesel fuel to within one inch of the top.
3. Double check the lid cover gasket position in the lid groove.
4. Attach the body to the lid and hand tighten the T-Bolt handle.

### D. Priming

1. Eliminate air — use existing fuel system primer, if so equipped. If not, remove the primer plug and fill to top with clean diesel fuel.
2. Start engine and check for leaks.

**NOTE:** For any marine or other unit utilizing the heat deflector shield, clean the shield to remove any accumulated diesel fuel.

# TROUBLESHOOTING

Engine starting and power loss problems from the fuel system are usually caused by one or more of the following:

### A. Air Leaks

1. **Fittings.** Ensure the O-Rings on the fittings in the DAHL filter ports are lubricated and not damaged, cracked or dirty.

**NOTE:** When using JIC 37° fittings, be sure only mating JIC 37° fittings are used. Misalignment will occur and air leakage will result from an attempt to fasten a 45° fitting to a JIC 37° fitting. Check for fitting looseness, seat dents, misalignment or unmatched threads. All fittings must be wrench tight.

2. **Bubbles In The Bowl.** If bubbles appear at the depressurizer cone, a leak is indicated between the fuel tank and the inlet port.

**NOTE:** Old fuel lines (rubber hose or metal tubing) may crack when moved. Check areas around push-on fittings, pipe adapters, hose clamps, etc. If air bubbles appear at the draincock, check for particles stuck in the valve seat or a partly open draincock. Also check for defective, miscentered or unlubricated bowl gaskets. Check the bowl plug O-Ring to make sure it is not cracked or extruded out of place. The bowl plug should be hand tightened only.

3. **Gaskets.** If the lid or bowl has been removed, make sure the gasket grooves are clean. Inspect the gaskets for proper seating in the grooves. Lubricate the lid cover gasket and the bowl gasket with grease.

### B. Clogging And Restriction

1. **Fuel Lines.** Check for collapsed lines caused by sharp bends or excessive turns. Check the tank and/or filter shut-off valve(s).
2. **Filter Elements.** Early clogging can occur from badly contaminated fuel (micro-organism growth, rust, sludge, dirt, etc.) Always carry a spare DAHL element. Asphaltic materials (fuel oxidation products), which are normally harmless to the injection system, can eventually plug original equipment filters remaining in the fuel system. If problems persist after the DAHL element has been replaced, also replace the other fuel filter elements.
3. **Filter Inlet.** Severely contaminated fuel may cause inlet plugging. In this event, close the fuel tank supply shut-off valve (if equipped) and disconnect the inlet line. Remove the bowl and clean the inlet. Should the depressurizer cone also be plugged, disassemble and clean out.
4. **Bleed Back.** If fuel in the DAHL filter bleeds back to the fuel tank, an air leak or reverse flow valve problem is indicated. Inspect fuel lines and fittings first as indicated above. If the reverse flow valve is clogged, use air or clean fuel to flush out.

### C. Malfunction Of Engine Parts

Pre-existing conditions in pumps and injectors can also cause power loss and engine starting problems. See your equipment dealer if the above troubleshooting guides do not cover your problem.

**WARNING:** Do NOT use gasoline or any form of alcohol or anything containing it inside or outside a DAHL Model 150 Series Fuel/Water Separator.

## REBUILD PROCEDURE

If it is ever necessary to dismantle the unit for inspection and/or possible repairs, refer to the parts illustration. Then follow these simple steps:

1. Refer to the appropriate ELEMENT REPLACEMENT steps for disassembly. (Dismount if desired.)
2. Remove the socket head bolts from the bowl ring to release the bowl. Stubborn bolts are easily removed by "shocking" the head. Place the allen wrench into the bolt and lightly rap the wrench with a hammer. Remove the bolt.
3. Unscrew the depressurizer cone to inspect the reverse flow valve.  
**Caution:** Cone edges are sharp. Use gloves or a rag for protection.

4. Check all parts for damage. Replace all damaged parts or hard gaskets. (Order Gasket Kit 150-GK.)
5. Refer to the parts illustration for reassembly. Clean all gasket grooves and contact surfaces of foreign matter. Coat the lid cover gasket and the bowl gasket with grease and all other gaskets and O-Rings with oil. Hand tighten the depressurizer cone and wrench tighten the socket head bolts.
6. Again, refer to ELEMENT REPLACEMENT section to finish reassembly.

## HOW THE DAHL SYSTEM WORKS

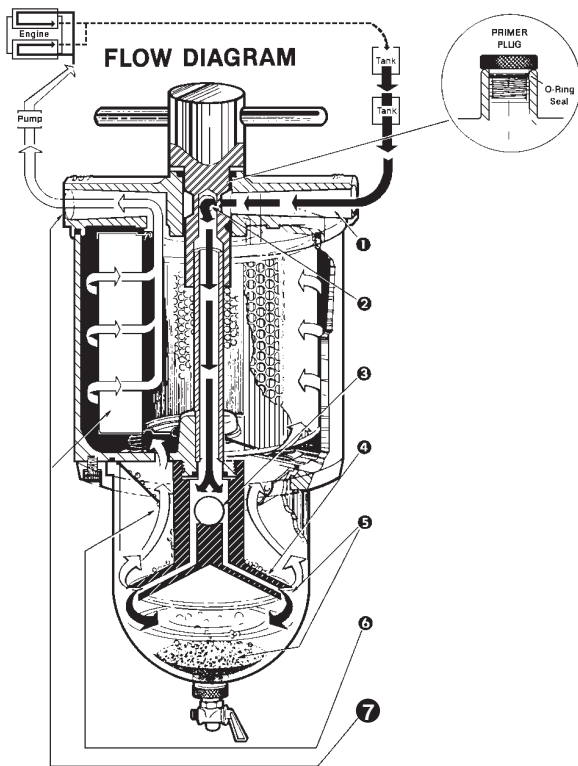

1. The contaminated fuel enters the inlet port.
2. The T-Bolt redirects the fuel downward through the centerpipe.
3. Fuel flows through the reverse flow valve.
4. Fuel flow is spread by the depressurizer cone.
5. As fuel is discharged from the depressurizer cone, 80% of contaminant separation takes place. Most of the solid particles and water settle into the quiet zone of the bowl.
6. As the fuel rises upward, any remaining minute water droplets coalesce on cone, baffle and bowl surfaces. Droplet size and weight gradually increase, causing downward flow into the sump.
7. Fuel is filtered completely by the element, which contains HydroShield™ media. The clean fuel then continues upward through the outlet port and on to the pump and injection system.

## MODEL 150 SPECIFICATIONS & PARTS

**Recommended Flow Rate:** 80 GPH (U.S.) (302 LPH)  
**Port Thread:** 7/8-14 w/O-Ring Boss  
**Height:** 14 1/4 In. (368.3 mm)  
**Width:** 6 In. (152.4 mm)  
**Depth:** 6 11/32 In. (161.1 mm)  
**Weight:** 9.5 lbs. (4.3 kg)

Item	Order #	Qty.	Description
1		1	T-Bolt
2		1	Lid Cover
3		1	Lid Cover Gasket (Incl. in 150-GK)
4		1	Centerpipe
5		1	Body
6		1	Bowl Gasket (Incl. in 150-GK)
7		1	Bowl Ring
8		1	Reverse Flow Washer (Incl. in 100-DEPR KIT & 150-GK)
9		1	Depressurizer Set (Incl. in 100-DEPR KIT)
10	150-31	1	Primer Plug
11		1	Primer Plug O-Ring (Incl. in 150-GK)
12		1	T-Bolt O-Ring (Incl. in 150-GK)
13		1	Lid O-Ring (Incl. in 150-GK)
14		1	Centerpipe O-Ring (Incl. in 150-GK)
15	151,-W,-30	1	Filter Element
16		1	Spring
17		4	Socket Head Bolt
18		1	Reverse Flow Gasket (Incl. in 100-DEPR KIT & 150-GK)
19		1	Reverse Flow Ball (Incl. in 100-DEPR KIT)
20	100-21	1	Bowl
21		1	Bowl Plug O-Ring (Incl. in 150-GK)
22	100-29	1	Bowl Plug
23	100-30	1	Draincock

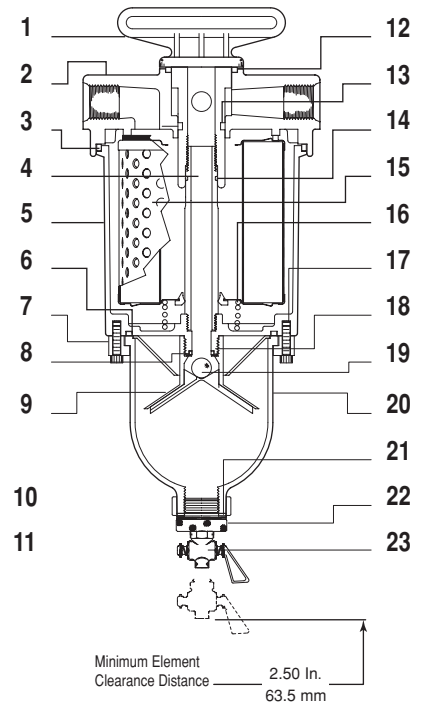
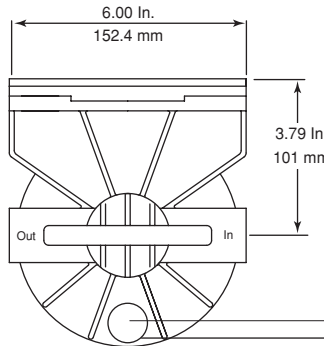
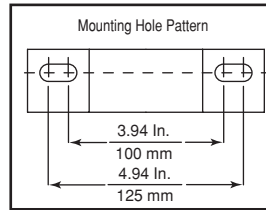

## MODEL 150-MFV SPECIFICATIONS & PARTS (OBS)

**Recommended Flow Rate:** 160 GPH (U.S.) (604 LPH)  
**Port Thread:** 3/4-14 NPT  
**Height:** 14 1/4 In. (368.3 mm)  
**Width:** 20 1/2 In. (520.7 mm)  
**Depth:** 6 11/32 In. (161.1 mm)  
**Weight:** 24 lbs. (10.8 kg)

Item	Order #	Qty.	Description
1		1	Manifold Bracket
2	150	2	Filter/Separator
3		4	90° Swivel 7/8 x 1/2 In.
4		4	1/2 In. Pipe-Thread Adapter
5		4	1/2 in Butterfly Shut-Off Valve
6		4	1/2 In. Close Nipple
7		1	3/4 x 1/2 x 1/2 In. Tee
8		2	1/2 In. Elbow
9		2	Long Nipple
10		1	Drilled & Tapped Tee
11		1	1/8 In. NTP Plug

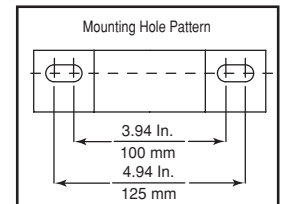
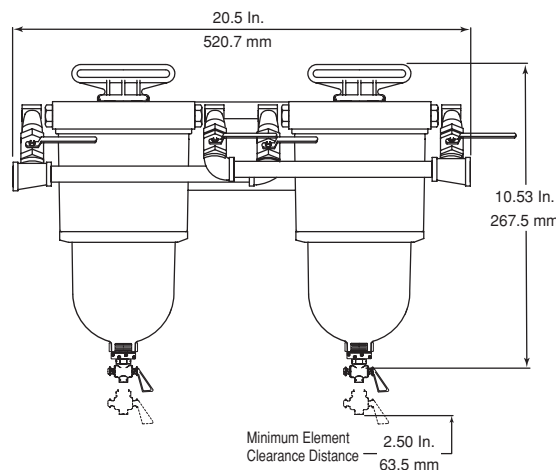
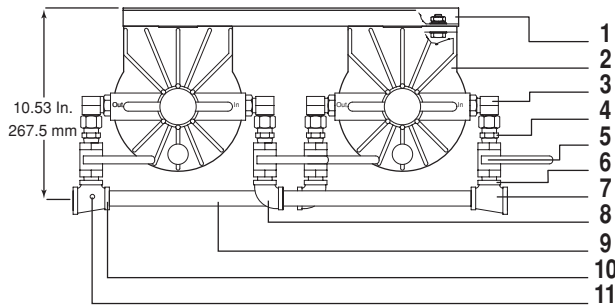

**NOTE:** For Aluminum Bowl and Marine Versions of the DAHL Model 150 Series, Refer to Form 4123.

# 150 SERIES

## DAHL FUEL/WATER SEPARATORS

### WHY DAHL?

Filters are a compromise wherever located. As a one-step strainer, a filter must be porous enough to allow sufficient flow volume. This means the filters which came with the equipment are usually in the 10-30 micron range.

However, if a more efficient media were used, the filter would become clogged very quickly, restricting the flow and resulting in frequent, costly element changes.

Not only that, many fuel filters are not designed to remove significant amounts of water, even though water is a primary cause of injector pump and nozzle damage.

Water and solid contaminants displace the diesel fuels lubricative coating on precision injection components. The loss of this protection results in wear, erosion, surface pitting and eventual fuel pressure loss.

### THE SOLUTION

DAHL's functional dual chamber, 3-stage diesel fuel filter/water separators provide efficient suction side water separation and contaminant filtration. The key is the unique DAHL patented depressurizer cone, which spreads the flow of the fuel. The fact is, the more area to flow over, the slower the flow and the greater the separation of water and dirt from the fuel. DAHL diesel fuel filter/water separators have less mechanical flow resistance because the fuel changes direction only once.

### BALDWIN LIMITED WARRANTY

Baldwin Filters, Inc. ("Baldwin") warrants that each new DAHL product manufactured by Baldwin will be made free of defects in workmanship and material and will perform in accordance with its specifications as follows:

1. Housings one year from date of user's purchase.
2. Replaceable Elements during equipment manufacturer's recommended filter service interval, if properly installed.

Baldwin will replace any product found to be defective when you return it to Baldwin or to your Baldwin distributor where you purchased the product.

#### Return Process

You should first contact your salesperson at Baldwin or at your Baldwin distributor if you purchased a product that you believe does not meet the warranty stated above. The salesperson will help you complete the necessary paperwork, and will also help you return the suspected defective product to Baldwin for analysis.

#### Warranty Fulfillment

If Baldwin finds that a returned product does not meet the warranty stated above, Baldwin will promptly replace the defective product. If the defective product directly caused damage to the machine on which it was installed, Baldwin will promptly reimburse the machine owner for that portion of the repair costs that were necessary to restore the machine to its condition immediately prior to the damage caused by the defective product.

#### Conditions

Baldwin's warranty fulfillment obligations above do not apply if: **a)** the product is not returned to Baldwin for analysis, **b)** Baldwin finds that the product was not defective, **c)** the product was improperly installed or used, **d)** the product was reused or not replaced inside a normal service interval, or **e)** the product is tampered with or damaged in a manner that may inhibit Baldwin's ability to conduct a warranty investigation. Baldwin does not warrant any products that it does not manufacture (e.g., electronics, pumps, motors, etc.). You must look exclusively to the manufacturer of those products for warranty coverage.

**The above warranty and warranty fulfillment obligations are exclusive and in lieu of all other warranties or related remedies.** Baldwin is not liable for indirect, incidental, punitive or consequential damages arising in any way from the products it manufactures or sells.

### COMPLETE EFFICIENCY

DAHL removes virtually 100% of the water and solid contaminants.

### PROVEN PERFORMANCE

DAHL diesel fuel/water separators have been tested and proven over millions of miles and hours under all sorts of conditions. Ask anyone who has used DAHL, or any Baldwin user, as Baldwin Filters makes DAHL products.

### MARINE DURABILITY

Marine units 75, 100-M, 150-M, 200-M, 200-MMV, 300-M and 300-MMV have passed severe U.L. testing. Tests include fire endurance, vibration fatigue, impact and thermal shock. These filters have also met U.S. Coast Guard requirements for Marine Applications.

### CLEAN FUEL

DAHL eliminates nearly all of the engine problems caused by water and solid contaminants in diesel fuel. In addition to saving you the cost of expensive repair bills and aggravation, you can expect:

- Longer Injection System Component Life
- Full Power Performance
- Less Element Replacement Cost

### SUPERIOR ENGINEERING

- Die Cast Aluminum
- Impact-resistant large transparent bowl
- Element service life is several times longer than conventional
- Easy to install, service and clean
- Positive air elimination
- Advanced spring design assures positive element seal
- Less mechanical resistance because of streamlined flow path
- Baffle system is designed to stop emulsification and disperse trapped air
- Ball check valve to stop reverse flow
- Six series specifically designed to fit diesel engines of various capacities

### Authorized Dealer



**WARNING:** These products can expose you to chemicals, including Diisononyl Phthalate, Carbon black extracts, Nickel, 1,3 Butadiene, Ethylene Oxide, Epichlorohydrin, which are known to the State of California to cause cancer, and Bisphenol-A, Ethylene Glycol, Ethylene Oxide, 1,3 Butadiene, Epichlorohydrin, which are known to the State of California to cause birth defects or other reproductive harm. For more information go to [www.P65Warnings.ca.gov](http://www.P65Warnings.ca.gov).