

# Parker Compressed Air Dryer

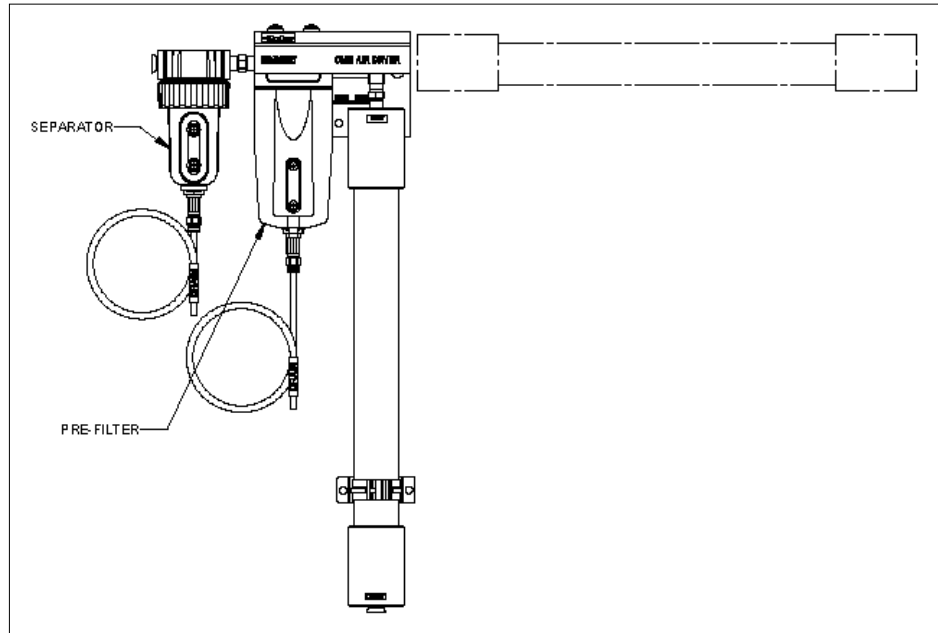

Figure 1 - Assembly Drawing

**These instructions must be thoroughly read and understood before installing and operating this product. Any modification of the unit will result in voiding the warranty. If you have any questions or concerns, please call the Technical Services Department at 800-343-4048, 8AM to 5PM Eastern Time (North America only). For other locations, please contact your local representative. Email us at: [balstontechsupport@parker.com](mailto:balstontechsupport@parker.com).**

### General Description

The Parker Compressed Air Dryer (see Figure 1) provides clean, dry compressed air from an existing compressed air supply through the use of state-of-the-art membrane technology. The dryers are capable of delivering dry air with a dewpoint of 35°F (2°C), depending on compressed air delivery pressure and flow rate. Flow capacities for the different models are compiled in the Specifications section of this bulletin (page 4). No electrical supply is required to use the Parker Compressed Air Dryer. Each dryer is equipped with a high capacity condensate separator and a high efficiency coalescing prefilter to remove oil, water, and particulate contamination to 0.01 micron. The Parker dryer is available with an additional prefilter for added protection in contaminated air streams.

### Installation and Operation

**All installation, operation, and maintenance procedures for the Parker Compressed Air Dryers should be performed by suitable personnel using reasonable care.**



**Warning: Use PTFE tape on all threaded components. Use of pipe sealants other than PTFE tape may damage the membrane and void the warranty.**

### Assembly

If your dryer system is unassembled, unpack the components and assemble as pictured above (see Figure 1). Following the flow arrow on the compressed air prefilter, attach the inlet of the membrane module to the outlet of the compressed air filter. A tee is provided to allow for vertical or horizontal configuration. (Note: The compressed air filter and separator must be mounted vertically, as shown.)

### Mounting

Mount the compressed air dryer to a vertical surface close to the point of use. **All mounting hardware should be adequately sized to support the weight of the dryer in its mounted position.**

## Compressed Air

The compressed air supply pressure should be between 60 psig and 150 psig (4.1 barg and 10.3 barg) for proper operation of the dryer. Dewpoints specified for saturated inlet air at 95°F (35°C) and 100 psig (6.9 barg) for optimal operation of compressed air system. **Do not exceed recommended inlet air temperatures or the performance and life of the module may be adversely affected and the warranty will be void.** If the dryer is located far from the receiver tank (D) or the air supply comes from an elevated air line, a drip leg must be installed directly upstream from the dryer. If the compressed air supply contains excess water and/or oil, install an additional coalescing prefilter (Grade DX) upstream from the compressed air dryer.

Flow control devices should be installed downstream from the dryer, or should be integral to the equipment the dryer is supplying. If the maximum flow rate of the dryer is exceeded, the output air may not meet the published dewpoint specification.

The compressed air dryers maintain a constant "sweep" flow to carry water vapor laden air away from the membrane module. This sweep flow may result in a constant "hiss" of air from the inlet end of the module. The total compressed air consumption of the dryer is the sum of the downstream demand plus the "sweep" flow (see specifications section, page 4). The compressed air supply should be adequately sized to supply this volume.

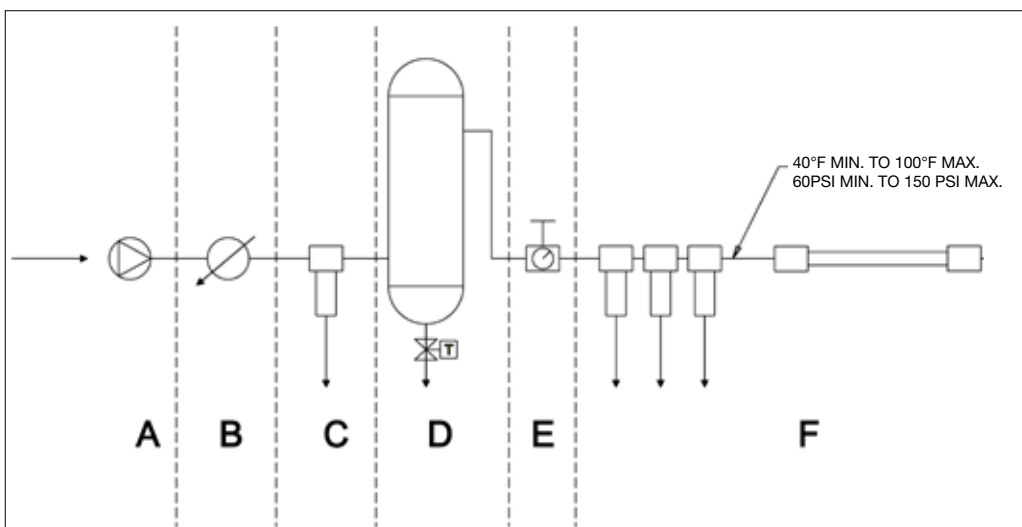

Figure 2 - Recommended Dryer Installation

- A Compressor:** Piston, screw, liquid ring\*, or vane compressor. Max pressure at the dryer 150 psig, min 60 psi.
- B Aftercooler:** Sized to bring the air temperature below 100°F (38°C).
- C Condensate Separators:** Install the first centrifugal separator in line after the aftercooler. This separator removes excess condensate from the cooling action of the aftercooler. Parker Hannifin recommends a second centrifugal separator after the receiver tank to remove excess condensate that may occur during warmer weather. Separators must be equipped with automatic drains.
- D Receiver Tank:** For vertical tanks, the air line should enter the tank in the lower 1/5<sup>th</sup> of the vessel, exit at the top 1/5<sup>th</sup>. For horizontal tanks, the air line should enter through the side of the tank and exit from the top. In either case, install a timed solenoid drain at base of tank.
- E Pressure Regulator:** Install to control line pressure and ensure that it does not exceed 150 psig at the dryer.
- F Dryer System:** Shown with three stages of filtration: Separator, DX grade (optional), BX grade. The DX grade may be optional in installations far from the compressor. Air flow must be controlled downstream from the dryer to prevent overflow operation.

Each drain line should be vented to atmosphere. Do not tie together. Assure that the ambient temperature does not exceed 100°F (38°C) and condensate collected according to local regulations.

\* In liquid ring compressors, steps should be made to eliminate sources of potential corrosion, such as chlorine from the compressor feedwater. The membrane dryer contains aluminum components which may corrode. Failure to follow these guidelines will void the warranty.

**Operation and Maintenance**

**Drain Lines**

The high efficiency coalescing prefilter integral to the compressed air dryer is equipped with an automatic drain. The drain will pass small quantities of water and compressor oil and should be piped away to a suitable containment device or drain, depending on local waste disposal requirements.

**Operation**

To operate the compressed air dryer, simply open the shutoff valve (customer installed) on the inlet air line, adjust the inlet air pressure using the (customer installed) pressure regulator, and adjust the outlet flow using the (customer installed) flow control device.

**Maintenance**



**Depressurize the dryer prior to performing any service.**

The only maintenance required by the compressed air dryer is the annual replacement of the prefilter cartridge and separator cartridge (see Figure 1).\*

The filter cartridges in the prefilter assemblies are removed by loosening the collar from the filter assembly or turning the bowl 90° counterclockwise, lowering the filter bowl away from the filter head, and unscrewing the element retainer from the base of the cartridge. Insert the new filter cartridge and reassemble the housing in reverse order. The time required to change the prefilter cartridge on the compressed air dryer is approximately 5 minutes. The separator cartridge can be accessed by unscrewing the collar and lowering the bowl away from the housing.

<b>Ordering Information</b> For Assistance, call toll-free at 1-800-343-4048 8AM to 5PM Eastern Time		
<b>Model Number</b>	<b>CM0080-35</b>	<b>CM0150-35</b>
<b>Replacement Prefilter Cartridges*</b>		
<b>Stage 1:</b>	PS702	PS802
<b>Stage 2:**</b>	–	5/100-12-DX
<b>Stage 3:</b>	5/100-12-BX	5/100-12-BX

\* To ensure consistent product performance and reliability use only genuine Balston replacement parts and filter cartridges.

\*\* DX Grade for -DX Models only.

Principal Specifications		
Model Number	CM0080-35	CM0150-35
Min/Max Inlet Air Temp.	40°F/120°F (4°C/49°C)	40°F/120°F (4°C/49°C)
Min/Max Ambient Air Temp.	40°F/120°F (4°C/49°C)	40°F/120°F (4°C/49°C)
Min/Max Inlet Pressure	60/150 psig (4.1/10 barg)	60/150 psig (4.1/10 barg)
Compressed Air Requirements	Total Air Consumption: Regeneration Flow + Outlet Flow Requirements (see table below)	
Max. Pressure Drop(2)	3psid	3 psid
Wall Mountable	Yes	Yes
Mechanical Separator (included)	F06F18B	F07F38B
Coalescing Prefilters(3)	2002N-0B1-BX (3)	B2004N-1B1-DX B2004N-0B1-BX
Inlet Port Size	1/4" NPT	1/2" NPT
Outlet Port Size	1/4" NPT	1/2" NPT
Electrical Requirements	None	None
Dimensions	24"l x 11.1"w x 4"d (61cm x 28.2cm x 6.3cm)	25"l x 16"w x 4.5"d (63.5cm x 40.6cm x 11.4cm)
Shipping Weight	6.68 lbs. (3 kg)	14.88 lbs.(6.75kg)

Flow Rates 35°F (2°C) Pressure Dewpoint (1)		
Model Number	CM0080-35	CM0150-35
Product Flow at 100 psig Inlet Pressure (scfm)	8	15
Product Flow at 101-150 psig Inlet Pressure (scfm)	8	15
Regeneration Flow at 100 psig (scfm)	1.5	2.7

Notes:

**1** Dewpoint specified for saturated inlet air at 95°F (35°C) and 100 psig (6.9 barg). Outlet flows will vary slightly for other inlet conditions.

**2** Total Air Consumption = Regeneration + Outlet Flow.

**3** If compressed air is extremely contaminated, a Grade DX prefilter should be installed directly upstream from the membrane dryer.

To activate your warranty go to [www.balstonfilters.com/warranty-registrations](http://www.balstonfilters.com/warranty-registrations).

**Parker Hannifin Corporation**  
 Filtration and Separation Division  
 242 Neck Road  
 Haverhill, MA 01835  
 Tel: 978-858-0505 Fax: 978-556-7501  
[www.balstonfilters.com](http://www.balstonfilters.com)

**Parker Hannifin (UK) Ltd**  
 Industrial Division  
 Suite 42, Kent House, Romney Place  
 Maidstone, Kent ME15 6LH United Kingdom  
 Tel: +44 (0)1622 772440 Fax: +44 (0)1622 772446  
[www.parker.com/pag](http://www.parker.com/pag)



For additional information call toll-free  
 (800) 343-4048  
 or  
 Visit our website  
[www.balstonfilters.com](http://www.balstonfilters.com)  
 email: [balstontechsupport@parker.com](mailto:balstontechsupport@parker.com)